

# NIKKON®

## GIANT LED FLOODLIGHT

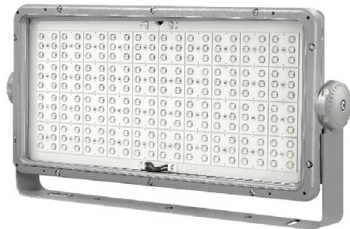

GIANT 450W



GIANT 900W



REMOTE CONTROL GEAR

### LUMINAIRE SPECIFICATIONS

- Power 450W  
900W
- Fitting Material Die-Case Aluminium
- Fitting Color Dark Gray
- Optical Cover Clear Tempered Glass
- Ingress Protection IP66
- Impact Protection IK08
- Voltage 220 ~ 240 Vac 50 / 60 Hz
- Power Factor  $\geq 0.9$  (at Full Load)
- Operating Temperature  $-30 \sim 45^{\circ}\text{C}$
- Installation Adjustable Mounting Bracket
- Surge Protections 10KV, 20 kA

### OPTIONAL FEATURES

- Beam Angle  $30^{\circ}$ ,  $60^{\circ}$ ,  $90^{\circ}$ , Asymmetrical

### LED MODULE SPECIFICATIONS

- Color Temperature 3000K, 5700K (Other CCT Upon Request)
- LED Chips 5050
- Color Rendering Index (CRI)  $R_a > 70$
- L70 100,000 Hrs @  $25^{\circ}\text{C}$
- PCB Material Metal Core

### COMPLIANCE STANDARD

- LED LM80, UL, RoHS
- Driver EN61347, EN55015, IEC/EN61000, EN62384

### APPLICATION

- Sport Lighting, Stadium Lighting, Jetties, Highmast

### MEASUREMENT & ORDER CODE

WATTAGE	NO. OF LEDS	LUMEN	CONSUMPTION	NETT WEIGHT
450W	240	66000	450W	11.5 kg + 10.5 kg
900W	480	132000	900W	24.6 kg + 13.75 kg

\* Please indicate LED color temperature and optic when ordering.

\* All result tested base on 5700K CCT LEDs.

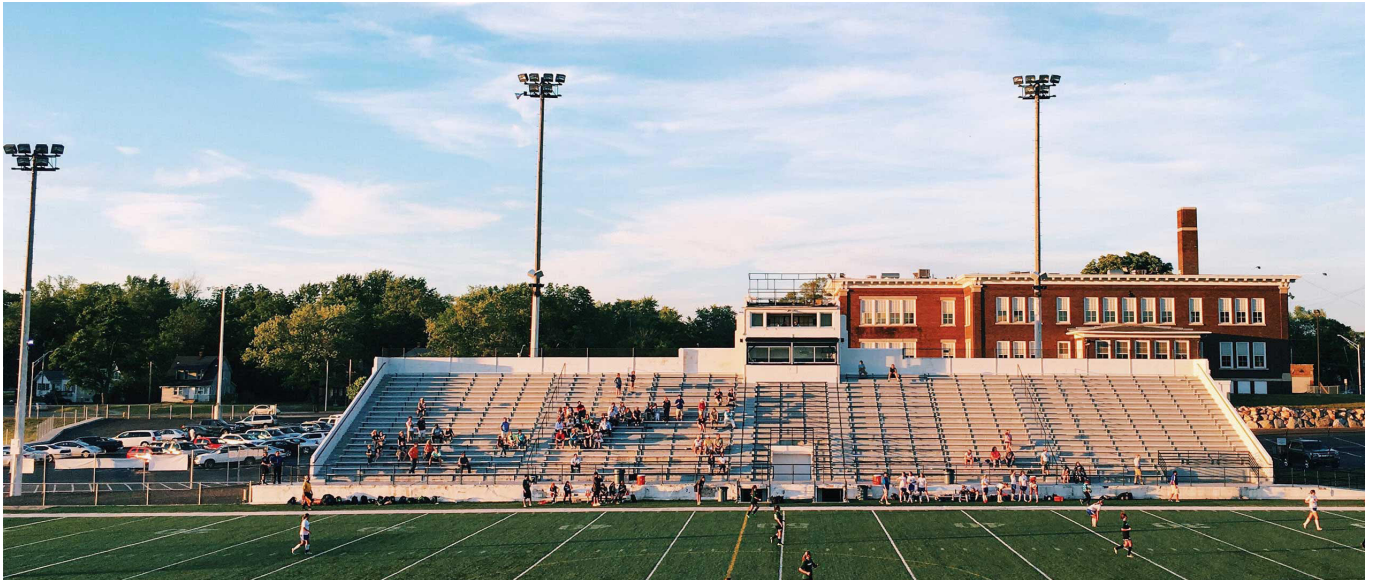

### DIMENSION

GIANT 450W

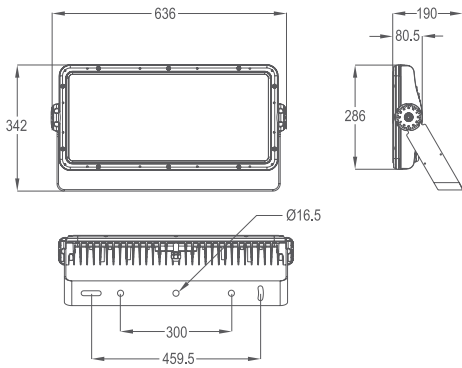

Remote Control Gear

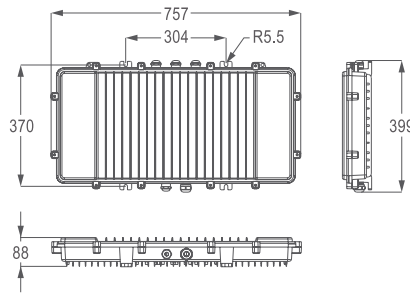

### PHOTOMETRIC

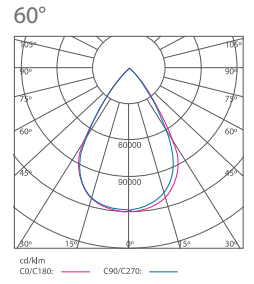
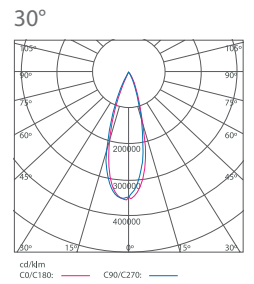

GIANT 900W

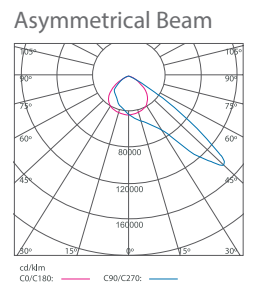
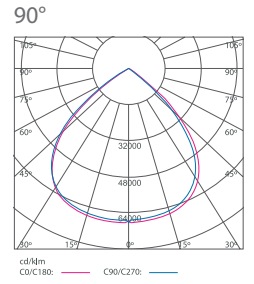
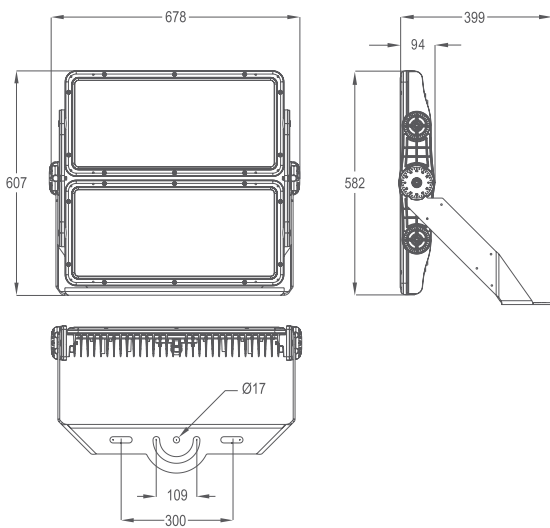

Note: All specifications are subject to change without prior notice for product improvement. Images are for illustrative purposes only.